



Name: _____

Grade: _____

SANDER

Operation and Safety



True
 False

Stock should be held flat and firmly on the table.

GIKNATCR TTNEUMDSJA

True
 False

Check the belt for correct tracking before operating.

TRIME GGUEA

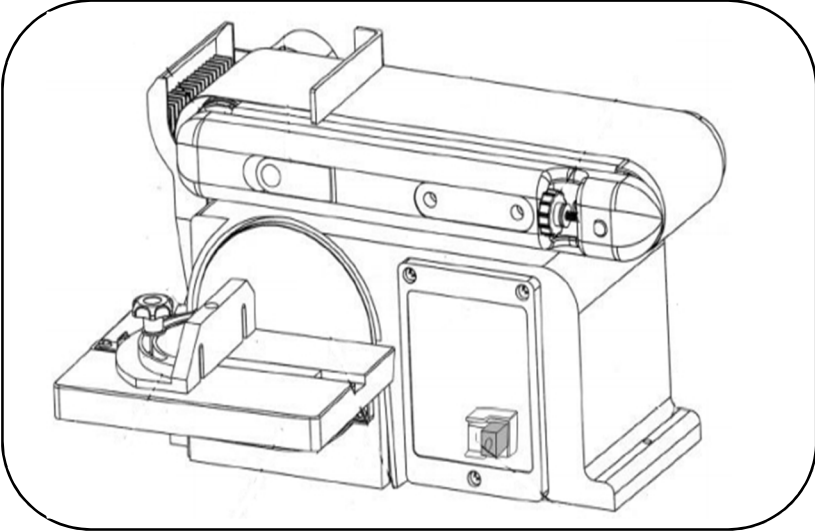

ELTB DNSERA

ONIENTS LREEV

WPOER OTTNBU

DCIS ANRESD

BLAET

What is the margin of safety on the belt and disc sander?

½"
 1"
 1 ½"

Stock should be kept constantly moving so it does not...

Avoid using belts or discs that are ...

Ripped
 Burned
 Leather

Belt Sander
 Disc Sander
 Miter Gauge
 Tracking Adjustment
 Table
 Tension Lever