



JOINTER SAFETY SHEET



Appropriate eye and personal protective equipment must be worn. Machines have moving parts that may cause entanglement. All loose clothing, jewelry and long hair must be secured.

OPERATE ONLY AFTER YOU HAVE RECEIVED INSTRUCTION AND YOUR TEACHER'S PERMISSION TO USE THIS TOOL. BE SURE YOUR TEACHER HAS CHECKED YOUR UNDERSTANDING OF PROPER PRACTICE.

Possible Risk Factors

- ✓ *Contact with moving parts.*
- ✓ *Eye Injuries*
- ✓ *Hearing Damage*
- ✓ *Hand Injuries*
- ✓ *Entanglement of hair, clothing or jewelry.*
- ✓ *Small and large projectiles*

1. Be sure to have the instructor's approval before operating the machine.
2. Before turning on the machine, make adjustments for depth of cut and position of fence.
3. Do not adjust out feed tables or remove guard without the instructor's approval.
4. The maximum cut for jointing an edge is 1/8" inch; for flat surface 1/16" inch.
5. Stock must be at least 12" inches long. Stock to be surfaced must be at least 3/8" inch thick, unless a special feather board is used.
6. Feed the work so the knives will cut "with the grain". Use only new stock that is free of knots, splits, and checks.
7. Keep your hands away from the cutter head even though the guard is in position. Maintain at least a 4" inch margin of safety
8. Use a push block when planing a flat surface. Do not plane the end grain unless the board is at least 12" inches wide.
9. The jointer knives must be sharp. Dull knives will vibrate the stock and may cause a kickback.



SAFETY GLASSES



EAR PROTECTION



SAFETY BOOT



WEAR DUST

Continue pushing stock through the jointer until you have completely cleared the blades and the rocker arm/guard has returned to the rest position

Never use your hand to guide stock through the jointer when it sits below the height of the fence.

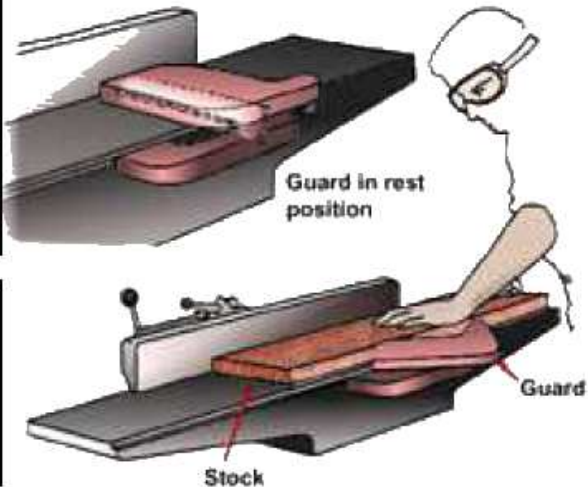



JOINTER SAFETY SHEET



Cutter head parts:

- 1 – Knife
- 2 – Throat Piece
- 3 – Throat
- 4 – Set Screws
- 5 – Key Plug

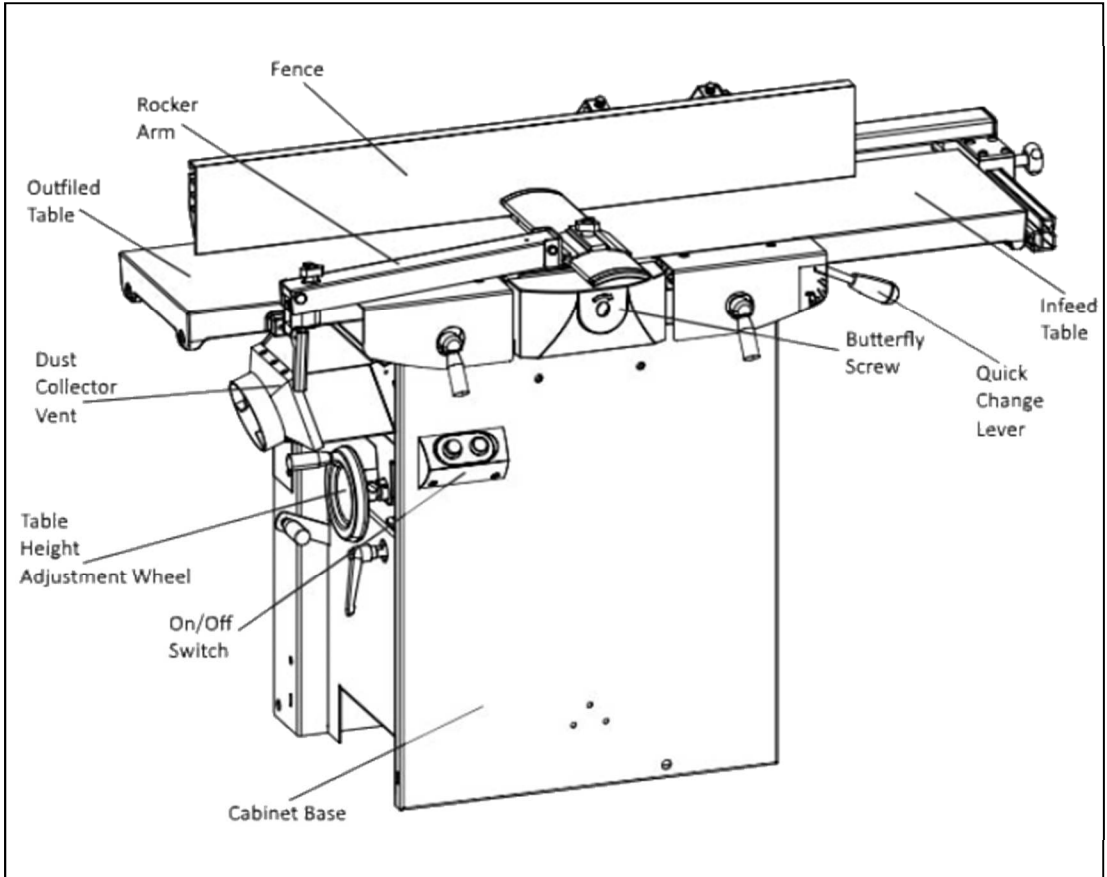
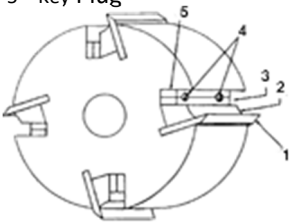

Pushstick

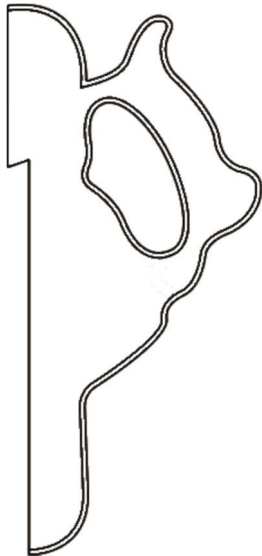

Push block

