

# BANDSAW

## BS500A

# Instruction Manual

### IMPORTANT

For your safety, read instructions carefully before assembling or using this product. Save this manual for future reference.



Original Instruction  
V.6-202010

### HEALTH AND SAFETY GUIDELINES

Always follow the instructions provided with the manual. Always wear safety glasses when using woodworking equipment. Always disconnect the power before adjusting any equipment. Failure to observe proper safety procedures and guidelines can result in serious injury.

**WARNING:** Do not allow familiarity (gained from frequent use of your machine and accessories) to become commonplace. Always remember that a careless fraction of a second is sufficient to inflict severe injury.



Always wear safety glasses when using woodworking equipment.



Always read the instructions provided before using woodworking equipment.

# INDEX

- 1 GENERAL INFORMATION
  - 1.1 FOREWORD
  - 1.2 MACHINE IDENTIFICATION
  - 1.3 CUSTOMER SERVICE RECOMMENDATIONS
- 2 SAFETY PRECAUTIONS
  - 2.1 SAFETY REGULATIONS
  - 2.2 RESIDUAL RISKS
  - 2.3 SAFETY AND INFORMATION SIGNALS
- 3 SPECIFICATIONS
  - 3.1 MAIN COMPONENTS
  - 3.2 TECHNICAL SPECIFICATION
  - 3.3 ELECTRICAL CONNECTION
  - 3.4 NOISE LEVEL
  - 3.5 DUST EXTRACTION
- 4 INSTALLATION AND OPERATION
  - 4.1 INSTALLATION ZONE CHARACTERISTIC
  - 4.2 LIFTING
  - 4.3 POSITIONING THE MACHINE
  - 4.4 BLADE MOUNTING AND ADJUSTMENT
  - 4.5 SETTING BLADE GUARD & GUIDE
  - 4.6 TILTING THE WORK TABLE
  - 4.7 FACE CUTTING
  - 4.8 CUTTING SHORT PIECES
  - 4.9 CUTTING OF ROUND PIECES
- 5 MAINTENANCE
- 6 TROUBLE SHOOTING
- 7 DIAGRAMS AND COMPONENTS

## 1. GENERAL INFORMATION

### 1.1 FOREWORD

Some information and illustrations in this manual may differ from the machine in your possession, since all the configurations inherent in the machine complete with all the optionals are described and illustrated. Therefore, refer only to that information strictly connected with the machine configuration you have purchased.

With this manual we would like to provide the necessary information for maintenance and proper use of the machine. The distribution network is at your service for any technical problem, spare parts or any new requirement you may have for the development of your activity.

This manual must be read and understood before operating the machine. This will provide a better working knowledge of the machine, for increased safety and to obtain the best results.

To facilitate its reading, the manual has been divided into sections pointing out the most important operations. For a quick research of the topics, it is recommended to consult the index. To better stress the importance of some basic passages, they have been marked by some preceding symbols:



#### **WARNING**

Indicates imminent risks which may cause serious injury to the operator or other persons. Be careful and scrupulously follow the instructions.



#### **CAUTION**

A statement advising of the need to take care lest serious consequences result in harm to material items such as the asset or the product.

## 1.2 MACHINE IDENTIFICATION

There is a identification plate fixed to the machine, containing the manufacturer's data, year of construction, serial number and technical specifications.

## 1.3 CUSTOMER SERVICE RECOMMENDATIONS

Apply the machine to skilled and authorized technical staff to carry out any operation dealing with parts disassembly. Keep to the instructions contained in this manual for the correct use of the machine.



### CAUTION

Only skilled and authorized staff shall use and service the machine after reading this manual. Respect the accident prevention regulations and the general safety and industrial medicine rules.

# 2. SAFETY PRECAUTIONS

## 2.1 SAFETY REGULATIONS



### WARNING

Read carefully the operation and maintenance manual before starting, using, servicing and carrying out any other operation on the machine.

The manufacturer disclaims all responsibilities for damages to persons or things, which might be caused by any failure to comply with the safety regulations.

- The machine operator shall have all necessary prerequisites in order to operate a complex machinery.
- It is prohibited to use the machine when under the influence of alcohol, drugs or medication.
- All the operators must be suitably trained for use, adjustment and operation of the machine.
- The operators must carefully read the manual paying particular attention to the warning and safety notes. Furthermore, they must be informed on the dangers associated with use of the machine and the precautions to be taken, and must be instructed to periodically inspect the guards and safety devices.
- Before carrying out adjustment, repair or cleaning work, disconnect the machine from the electric power by setting the main switch to stop.
- After an initial bedding-in period or many hours of operation, the driving belts may slacken; this causes an increase in the tool stopping time (the stopping time must be less than 10 seconds). Immediately tighten them.
- The working area around the machine must be kept always clean and clear, in order to have an immediate and easy access to the switchboard.
- Never insert materials which are different from those which are prescribed for the machine utilization. The material to be machined must not contain any metal parts.
- Never machine pieces which may be too small or too wide with respect to the machine capacity.
- Do not work wood which has evident defects (cracks, knots, metal parts, etc.)
- Never place hands among the moving parts and/or materials.
- Keep hands clear from the tool; feed the piece with the aid of a pusher.
- Keep the tools tidy and far away from those not authorized persons.
- Never employ cracked nor unbalanced, neither not correctly ground tools.
- Never use the tools beyond the speed limit recommended by the producers.
- Carefully clean the rest surfaces of tools and make sure that they find perfectly horizontally positioned, and with no dents at all.
- Always wear gauntlets when handling the tools.
- Mount the tools in the right machining direction.
- Never start the machine before having correctly installed all the protections.
- Connect the dust suction hoods to an adequate suction system; suction must always be activated when the machine is switched on.
- Never open doors or protections when the machine or the system is operating.
- Many unpleasant experiences have shown that anybody may wear objects which could cause serious accidents. Therefore, before starting working, take any bracelet, watch or ring off.
- Button the working garment sleeve well around the wrists.
- Take any garment off which, by hanging out, may get tangled in the MOVING UNITS.
- Always wear strong working footwear, as prescribed by the accident-prevention regulations of all countries.
- Use protection glasses. Use appropriate hearing protection systems (headsets, earplugs, etc.) and dust protection masks.

- Never let unauthorized people repair, service or operate the machine.
- The manufacturer is not responsible for any damage deriving from arbitrary modifications made to the machine.
- Any transport, assembly and dismantling is to be made only by trained staff, who shall have specific skill for the specified operation.
- The operator must never leave the machine unattended during operation.
- During any working cycle break, switch the machine off.
- In case of long working cycle breaks, disconnect the general power supply.

## 2.2 RESIDUAL RISKS

Despite observance of all the safety regulations, and use according to the rules described in this manual, residual risks may still be present, among which the most recurring are:

- contact with tool
- contact with moving parts (belts, pulleys, etc..)
- recoil of the piece or part of it
- accidents due to wood splinters or fragments
- tool insert ejection
- electrocution from contact with live parts
- danger due to incorrect tool installation
- inverse tool rotation due to incorrect electrical connection
- danger due to dust inhalation in case of working without vacuum cleaner.

Bear in mind that the use of any machine tool carries risks.  
Use the appropriate care and concentration for any type of machining (also the most simple).  
**The highest safety is in your hands.**

## 2.3 SAFETY AND INFORMATION SIGNALS

This signals may be applied on the machine; in some cases they indicate possible danger conditions, in others they serve as indication.

Always take the utmost care.

SAFETY SIGNALS:



Risk of eye injury. Wear eye protection.



Wear hearing protection systems.



Danger of electric shock. Do not access the area when the machine is powered.



Carefully read and understand the manual before using the machine.

INFORMATION SIGNALS:

Indicate the technical characteristics, direction of rotation and inclination, block and release, etc.

Carefully following the directions to simplify the use and adjustment of the machine.

The signals are graphically described and do not require further explanation.

# 3. SPECIFICATIONS

## 3.1 MAIN COMPONENTS

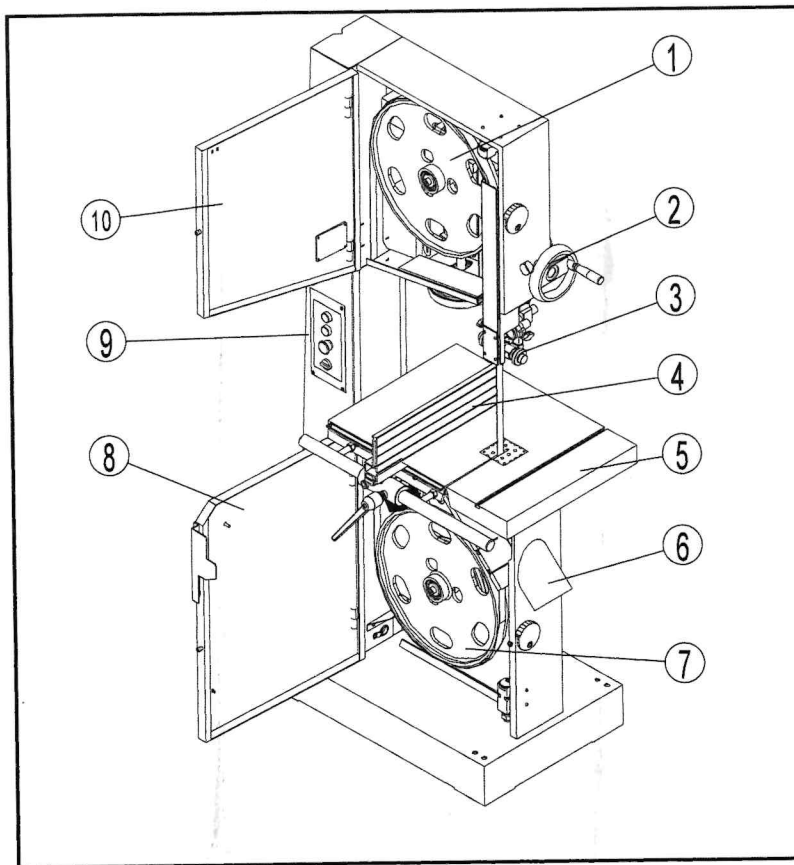

- 1 - Upper wheel
- 2 - Upper guide lifting handwheel
- 3 - Upper guide
- 4 - Rip fence assembly
- 5 - Table
- 6 - Dust port
- 7 - Lower wheel
- 8 - Lower door
- 9 - Switch with electric brake
- 10 - Upper door

## 3.2 TECHNICAL SPECIFICATION

Motor Voltage	220V/60HZ
Current	17A
Motor power output	4HP
Blade length	3962mm
Blade width	6 - 30mm
Max. cut depth	305mm
Throat width	480mm
Blade speed	1500m/min
Table size	633x485mm
Table tilt	0 - 45°
Dust port diameter	100mm

### 3.3 ELECTRICAL CONNECTION

- Electrical installation should be carried out by competent, qualified personnel.
- The mains connection should be made using the terminal box.
- Replacement of the power supply cable should only be done by a qualified electrician.



#### WARNING

To avoid electrocution or fire, any maintenance or repair to electrical system should be done only by qualified electricians using genuine replacement parts.

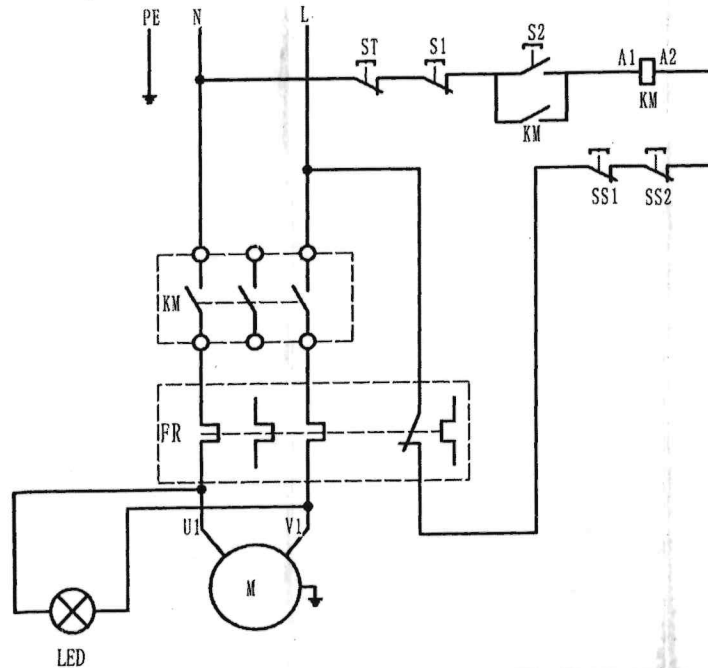

### 3.4 NOISE LEVEL

	No load	Load
Sound Pressure Level	< 80dB(A)	< 90dB(A)
Sound Power Level	< 90dB(A)	< 100dB(A)

The noise levels measured are emission levels and not necessarily the safe working level. Although there is a correlation between the emission levels and the exposure levels, this cannot be used reliably to determine whether or not further precautions are required. The factors which affect the actual level of operator exposure include the duration of exposure, the ambient characteristics and other sources of emission, for example, the number of machines and other adjacent machining. The permitted exposure values may also vary from country to country. Nevertheless, this information allows the user of the machine to better evaluate the dangers and risks.

Other factors which reduce exposure to noise are:

- correct tool choice
- tool and machine maintenance
- use of hearing protection systems (e.g. headsets, earplugs,...)



#### WARNING

Please use the hearing protection systems if the above mentioned noise levels exceed 95dB(A).

### 3.5 DUST EXTRACTION

If this band saw is operated indoors it is recommended to have it connected to a dust collector. The suction connector, supplied with the machine, has to be fitted to the dust ejection port of the saw for this purpose. The diameter of the suction connector is 100mm (4").

- Workmen working in operations processing oak or beech timber were found to develop more often cancer of the mucous membrane of the nose (adenocarcinoma of the inner nose) than other workers.

- Experience shows that skin contact with oak or beech dust does not cause cancer



**WARNING** Wood dust and chips, together with an ignition source and the oxygen in the ambient air, can cause fires and explosions, injuries and allergies.

## 4. INSTALLATION AND OPERATION

### 4.1 INSTALLATION ZONE CHARACTERISTICS



#### **WARNING**

It is prohibited to install the machine in explosive environments.

The installation zone must be selected evaluating the work space required depending on the dimension of the pieces to be machined, and taking into account that a free space of at least 800 mm must be left around the machine. It is also necessary to check the floor capacity and its surface, so that the machine base is evenly resting on its four supports. A power outlet and a chip-suction system connection shall be close to the selected machine setting and it must be conveniently lighted.

### 4.2 LIFTING

The machine can be lifted using a fork-lift truck, placing the forks under the feet or by using a "SLING", as shown, with a lifting capability of 2000 Kg.

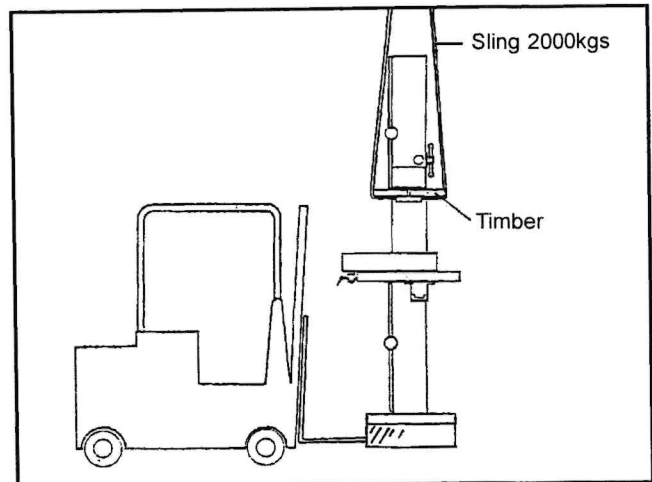

Fig.4.2

### 4.3 POSITIONING THE MACHINE

For a correct and rational organisation of the work area :

- Install the machine in an area that will not amplify vibration or noise
- Verify that the work area is adequately illuminated.
- When placed between other machinery there should be a space of at least 80 cm. It is necessary to anticipate sufficient space for cutting long work pieces transversely and for the fitting of rollers or other types of support, in front and at the rear of the table.

There are four holes for fixing the machine to the floor. When fixing to the floor it is recommended not to over tighten the fixtures to avoid increasing vibration. It is also advisable to place anti-vibration materials between the floor and the feet of the machine.

## 4.4 BLADE MOUNTING AND ADJUSTMENT

- To mount blade first remove the table insert (A of FIG.4.4.1) Place the blade onto the bandwheel checking the teeth are in a correct position, and then tighten the tension using the handwheel (A of FIG.4.4.2). The correct tension value is indicated on the tension scale inside the upper door, the indicated value corresponds to the width of the blade.

- Turn the bandwheels manually, checking that the blade does not interfere with any fixed parts and that the blade is placed correctly on the bandwheels. The points of the teeth should slightly protrude over the edge of the bandwheels. To adjust the blade position on the bandwheels slacken the locking lever (B of FIG.4.4.2), and then turn the knob (C of FIG.4.4.2): the blade will move inwards when turn the knob clockwise and the blade will move further out when turn the knob anticlockwise; A quarter of one circle is sufficient to make a noticeable displacement. Tighten the locking lever after the blade is positioned correctly.

- Then reinstall the table insert, close the band wheels accessing doors.



### CAUTION

After use we recommend slackening the blade tension, and to display a visible sign on the machine advising of this procedure. Remember to check and re-tension before use. This operation prevents damage to the bandwheel tyres.

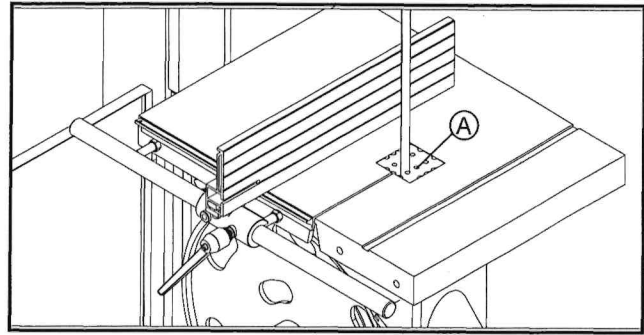

Fig.4.4.1

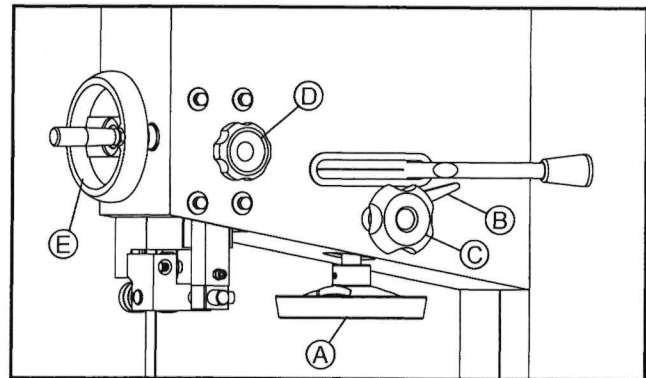

Fig.4.4.2

## 4.5 SETTING BLADE GUARD & GUIDE

### ADJUSTING THE SAW BLADE GUARD

The adjustable saw band guard should be positioned as close as possible to the workpiece. To adjust the height, release the locking knob (D of Fig.4.4.2) and turn the handwheel (E of Fig.4.4.2) to adjust the guard up or down. Lock the knob once the correct position of guard is obtained.

This operation must always be carried out while the machine is stopped.

### ROLLER BEARINGS BLADE GUIDE

The roller bearings should lightly touch the blade, to prevent vibration during operation and ensure correct direction of cutting. The positioning of these bearings is controlled by screw "A" (Fig.4.5.1), once they have been adjusted, tighten the screw "A" (Fig.4.5.1); they should be 2mm behind the teeth of the blade. The rear bearing prevents excessive backward movement of the blade whilst in operation, and should be 1-2 mm from the back of the blade: this can be adjusted by screw "B" (Fig.4.5.1).

### LOWER SAW BLADE GUIDE

- To roller bearing should lightly touch the blade, to prevent vibration during operation and ensure correct direction of cutting. The positioning of these rollers is controlled by screw "A" (Fig.4.5.2), once they have been adjusted, tighten the screw "A" (Fig.4.5.2); they should be 2 mm behind the teeth of the blade. The thrust shaft prevents excessive backward movement of the blade whilst in operation, and should be 1-2 mm from the back of the blade: this can be adjusted by screw "B" (Fig.4.5.2).

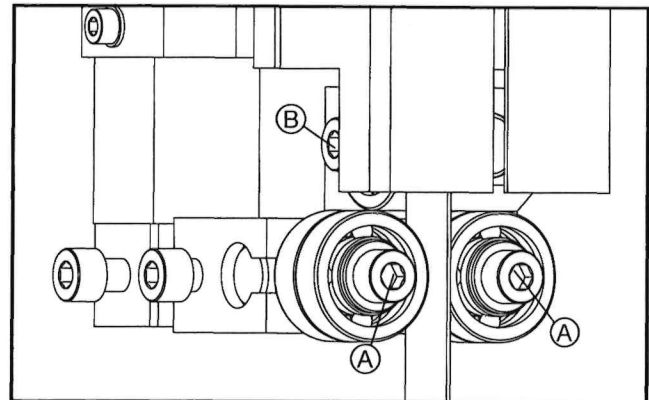

Fig.4.5.1

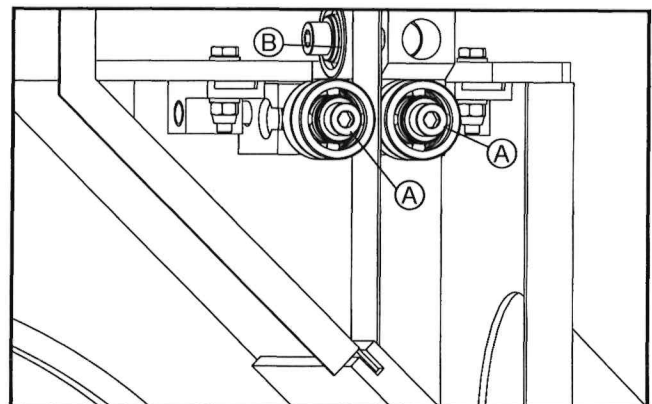

Fig.4.5.2



## 4.6 TILTING THE WORK TABLE

- The table may be set at 90degree to the blade by adjusting the table stop screw under the table. The table stop screw rests on the top of the lower wheel bandwheel housing. By first slackening the locking nut A and then adjusting the screw B, the table can be set correctly. Retighten the locking nut A making sure that the setting is maintained.

- To make adjustments of table tilting, slackening the locking handle D, and rotate the shaft C with special handle which you can find it in your loose parts bag whith this machine. When adjustment is correctly finished, tighten the handle D to lock it.

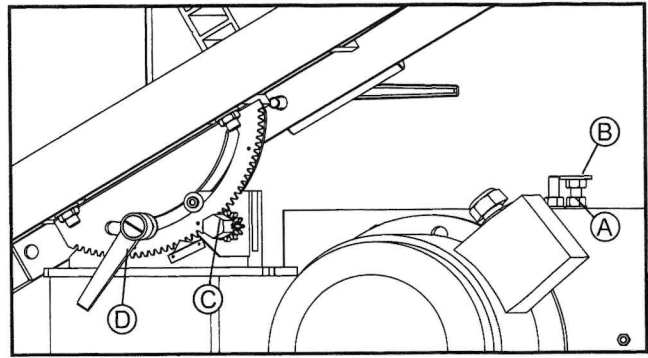

Fig.4.6

## 4.7 FACE CUTTING

Use a square for safe guiding of the work during face cutting. (FIG.4.7)

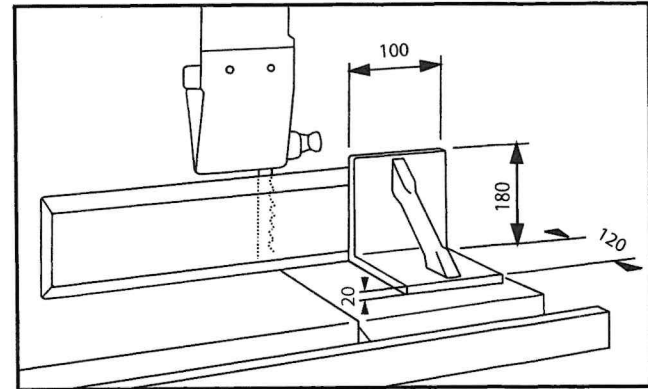

Fig.4.7

## 4.8 CUTTING SHORT PIECES

Use pushing devices for cutting of short pieces. The pushing device type A is recommended for narrow pieces.

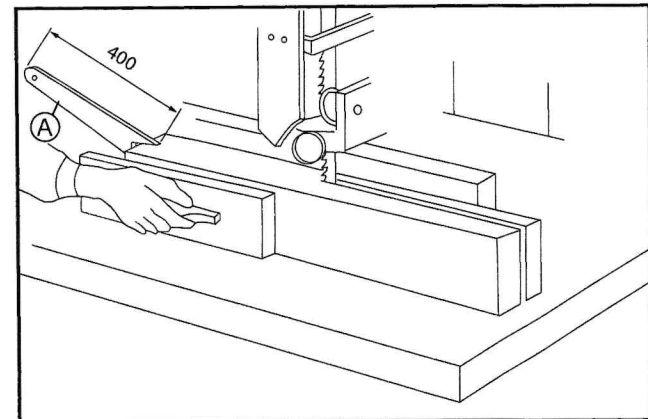

Fig.4.8

## 4.9 CUTTING OF ROUND PIECES

Use a wedge rest to prevent rotation of round parts during cutting.

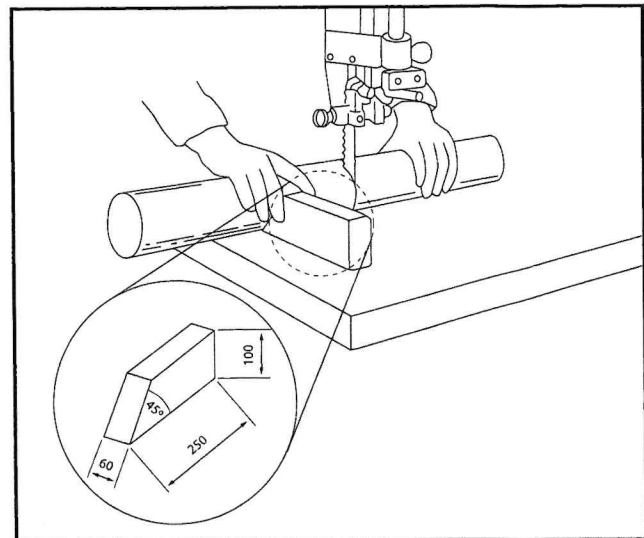

Fig.4.9

# 5. MAINTENANCE



**BEFORE ANY INTERVENTION ALWAYS DISCONNECT THE ELECTRICAL SUPPLY BY PLUG OUT!**  
Periodically check that all screws are tightly fastened and the condition of the various guards

## - V BELTS

After the first few hours of operation it is necessary to check that the tension of the belts is correct, as they tend to stretch. To control the tension of the belts push the mid-point of the belt applying 3-4 Kg of pressure, the displacement should not exceed 5-6 mm. It is recommended that the correct blade tension is maintained as loose belts reduce the motor power and can increase the braking time. Belts that are too tight can cause the belts to become hot .

## - TO CHANGE THE BELTS

Slacken the blade tension , remove the screw at the center of lower bandwheel, pull-out the bandwheel from the shaft, repeat the operations in reverse to re-assemble.

## - DISMANTLING THE UPPER BANDWHEEL

Remove the upper bandwheel is same as the operations of lower bandwheel.

## - REPLACEMENT OF RUBBER COVERING OF THE FLY-WHEELS

It is recommended that this be carried out by a competent specialist or the manufacturer, this is because the rubber covering is not only glued onto the bandwheel, but also ground in a crown form. It is strongly advised not to grind and shape the rubber directly on the machine using gouges, files or abrasives.

## - CLEANING AND LUBRICATING

Periodically clean the inside of the machine with the aid of a dust extractor for any saw-dust deposits, remove any resinous deposits from the bandwheels surface. The bandwheel bearings do not require any greasing. It is not necessary to lubricate any part or component of the machine as the sawdust circulating within will adhere to any oiled or greased surface jeopardizing the sliding of moving parts such as the shaft of the blade guide adjustment and the slide of the tensioning group.

Frequently control the cleanliness of the rubber surfaces on the bandwheels, particularly in cases of cutting resinous materials or chip-board. Clean the surfaces, while machine is not in motion , of any resinous deposits taking care do not damage the surface.

# 6. TROUBLE SHOOTING



## WARNING

- For any information or problem contact your area dealer or our technical service center. The necessary interventions must be carried out by specialised technical personel.
- Before carrying out any fault service or maintenance work, please always TRUN OFF THE SWITCH, UNPLUG POWER CABLE, WAIT FOR SAW BLADE TO COME TO STANDSTILL.

### Troubleshooting

Trouble	Possible Cause	Solution
<b>Saw stops or will not start</b>	<ol style="list-style-type: none"> <li>1. Saw unplugged</li> <li>2. Fuse blown or circuit breaker tripped</li> <li>3. Cord damaged</li> </ol>	<ol style="list-style-type: none"> <li>1. Check plug connections</li> <li>2. Replace fuse or reset circuit breaker</li> <li>3. Replace cord</li> </ol>
<b>Does not make accurate 45° or 90° cuts</b>	<ol style="list-style-type: none"> <li>1. Stop not adjusted correctly</li> <li>2. Angle pointer not set accurately</li> <li>3. Miter gauge out of adjustment</li> </ol>	<ol style="list-style-type: none"> <li>1. Check blade with square and adjust stop</li> <li>2. Check blade with square and adjust pointer</li> <li>3. Adjust miter gauge</li> </ol>
<b>Blade wanders during cut</b>	<ol style="list-style-type: none"> <li>1. Fence not aligned with blade</li> <li>2. Warped wood</li> <li>3. Excessive feed rate</li> <li>4. Incorrect blade for cut</li> <li>5. Blade tension not set properly</li> <li>6. Guide bearings not set properly</li> </ol>	<ol style="list-style-type: none"> <li>1. Check and adjust fence</li> <li>2. Select another piece of wood</li> <li>3. Reduce feed rate</li> <li>4. Change blade to correct type</li> <li>5. Set blade tension according to blade size</li> <li>6. Review guide bearing adjustment on pages 8 &amp; 9</li> </ol>
<b>Saw makes unsatisfactory cuts</b>	<ol style="list-style-type: none"> <li>1. Dull blade</li> <li>2. Blade mounted wrong</li> <li>3. Gum or pitch on blade</li> <li>4. Incorrect blade for cut</li> <li>5. Gum or pitch on table</li> </ol>	<ol style="list-style-type: none"> <li>1. Replace blade</li> <li>2. Teeth should point down</li> <li>3. Remove blade and clean</li> <li>4. Change blade to correct type</li> <li>5. Clean table</li> </ol>
<b>Blade does not come up to speed</b>	<ol style="list-style-type: none"> <li>1. Extension cord too light or too long</li> <li>2. Low shop voltage</li> </ol>	<ol style="list-style-type: none"> <li>1. Replace with adequate size and length cord</li> <li>2. Contact your local electric company</li> </ol>
<b>Saw vibrates excessively</b>	<ol style="list-style-type: none"> <li>1. Base on uneven floor</li> <li>2. Bad V-belt</li> <li>3. Motor mount is loose</li> <li>4. Loose hardware</li> </ol>	<ol style="list-style-type: none"> <li>1. Reposition on flat, level surface</li> <li>2. Replace V-belt</li> <li>3. Tighten motor mount hardware</li> <li>4. Tighten hardware</li> </ol>

# 7. DIAGRAMS & COMPONENTS

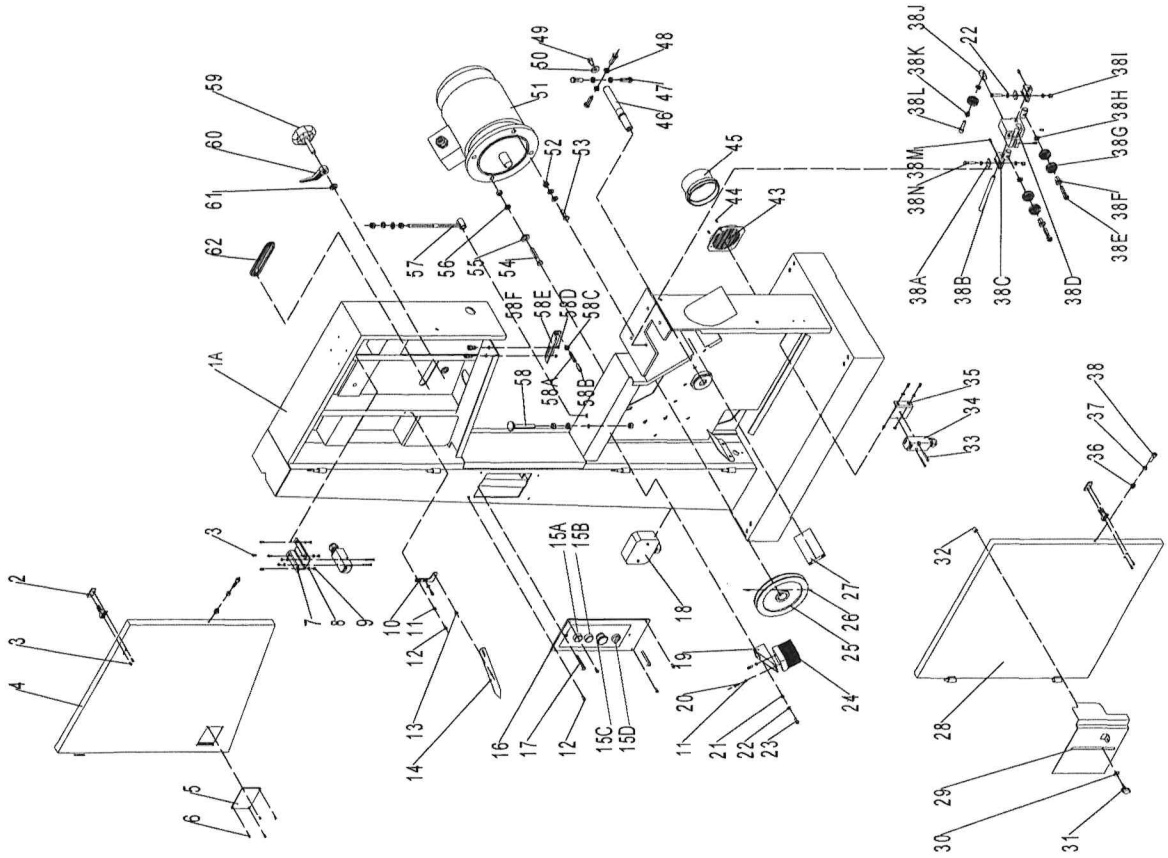

NO.	Description	Part NO.	Qty	NO.	Description	Part NO.	Qty.
1	frame plate	BS500101000B-124U	1	38D	Bracket	BS5001032002	1
2	Pan head screw	JL27010017	2	38E	screw	M8X40GB70Z	2
3	upper door	M4X10GB818Z	10	38F	tube	JL26041002	2
4	glass of window	BS5001012001A-060U	1	38G	bearing	BRG6201-2RSGB276	5
5	self-plugging rivet	JL26010001	1	38H	big washer	WSHG8GB97D1Z	3
6	microswitch base	RVT3X7GB12618A	4	38I	Lock nut	M6GB889Z	2
7	flat washer	JL26010012-124U	8	38J	Guide shaft	JL26041003	3
8	Hex bolt	M4GB6170Z	8	38K	Bearing tube	JL26041006	1
9	Bracket	JXBS2201010007	4	38L	screw	M8X30GB70Z	1
10	flat washer	WSHG5GB97D1Z	4	38M	Set screw	M6X10GB80B	4
11	Pan head screw	M5X10GB818Z	6	38N	Hex bolt	M6X30GB5783Z	2
12	Pointer screw	JL26010010	1	39			
13	Indicator	JXBS2401010002-105U	1	40			
14	Start switch	LA39-B2-10-g	1	41			
15A	Stop Switch	LA39-B2-01-f	1	42			
15C	Emergency Switch	A22-E-S-K01	1	43	Suction grille	JL20010019-001S	1
15D	Two Position knob	PB1S-21XD-W31	1	44	self tapping screw	ST3D5X9D5GB845Z	2
16	switch plate	BS4001010004-124U	2	45	Suction	JL20010007-001S	1
17	self tapping screw	ST3D5X28GB845B	1	46	Lower shaft	JXBS2001020002	1
18	Three-phase seat type plug	PZ26E-03A	1	47	Hex bolt	M12X35GB5783Z	4
19	Brush base	JL29000009-124U	1	48	hex nut	M12GB6172Z	4
20	self tapping screw	ST4D8X16GB845Z	2	49	screw	M10X20GB70Z	1
21	Hex nut	M6GB6172Z	1	50	big washer	WSH10GB96Z	1
22	flat washer	WSHG6GB97D1Z	7	51	motor	YSH105304	1
23	screw	M6X12GB70Z	1	52	Hex bolt	M10GB6170Z	5
24	Brush	JL29000004	1	53	Hex bolt	M10X40GB5783Z	1
25	motor pulley	BS5001020003-001G	1	54	Hex bolt	M10X70GB5783Z	1
26	screw	M8X10GB80B	2	55	big washer	WSH10GB96Z	1
27	Plate	JXBS2401010014	1	56	plat washer	WSH10GB97D1Z	6
28	lower door	BS5001012002A-060U	1	57	Shaft	BS5001015001	1
29	Protection cover	BS4001012003-146T	1	58	support screw	JXBS2001010003	1
30	big washer	WSHG6GB96Z	1	58A	Set screw	M6X30GB77B	1
31	Wing knob	JXBS2401054001-001S	1	58B	plastic tube	JXBS2401010018	1
32	nut	M6X15GB/T17880D3Z	4	58C	screw	M6GB6170Z	2
33	Pan head screw	M4X30GB818Z	2	58D	screw	M5GB6170Z	2
34	microswitch	QKSS	2	58E	Connecting angle	BS5001010002	1
35	microswitch base	JL27010016-124U	2	58F	screw	M5X16GB70Z	2
36	Lock nut	M6GB889Z	2	59	adjusted handle	JXBS2401010006-001S	1
37	tube	JL26010007	2	60	locker	JXBS2401010007-001S	1
38	screw	M6X20GB70Z	2	61	plat washer	WSH12GB97D1Z	1
38A	Plate	JL22040004	1	62	dust blocking plate	JL26030019	1
38B	Connection shaft	BS5001032003	1				
38C	Bracket	JL20043001	2				

Frame Assembly

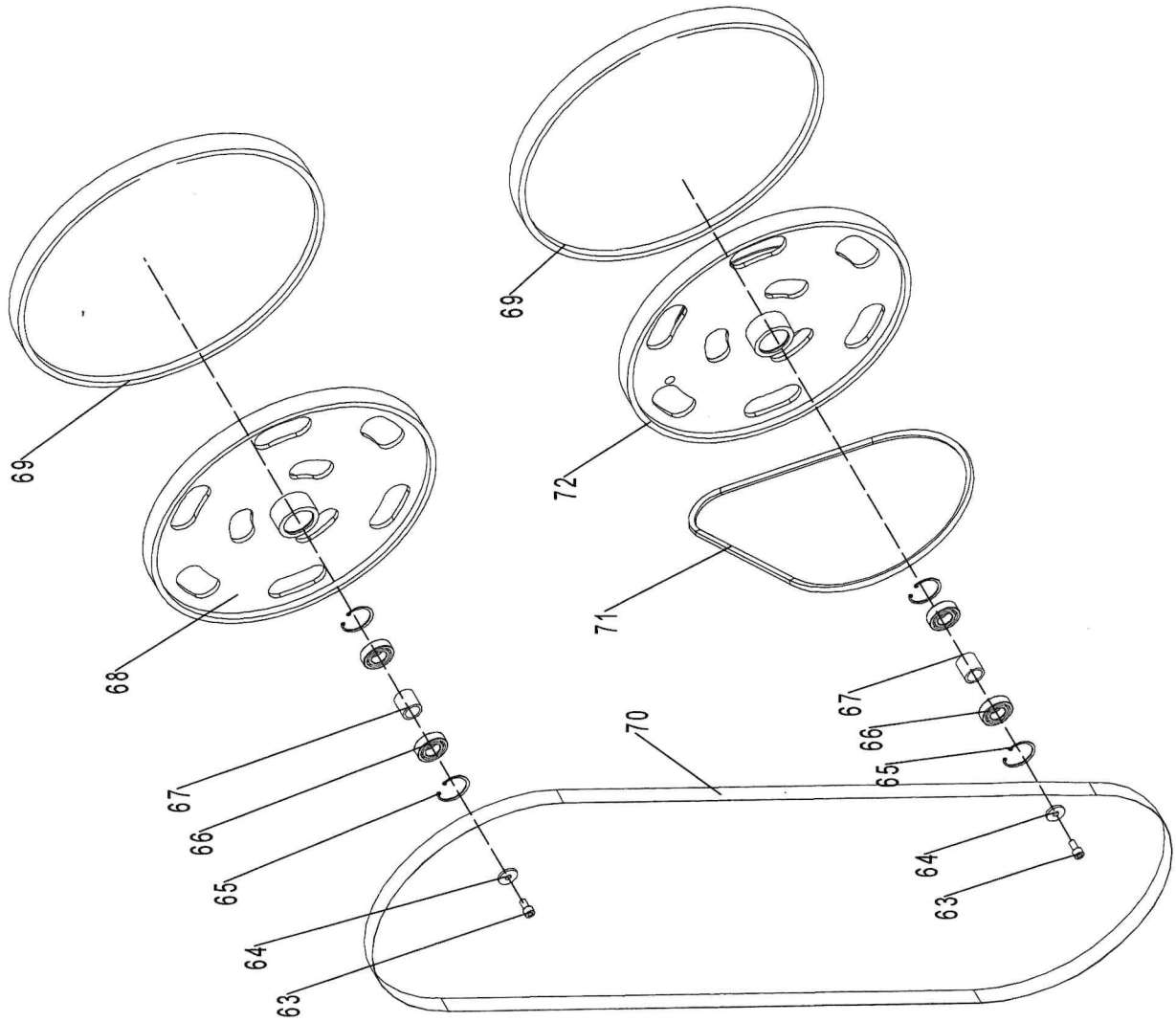

NO.	Description	Part NO.	Qty.
63	Screw	M10X20GB70Z	2
64	Washer	JXBS2201020004	2
65	Retaining ring	CLP52GB893D1B	4
66	Bearing	BRG6205-2RSGB276	4
67	Tube	BS5001022002	2
68	Upper wheel	BS5001021001A-001G	1
69	Tire	BS5001021002A	2
70	Blade	BS5001020001	1
71	Belt	BS5001020002	1
72	Lower wheel	BS5001022001A-001G	1

Driving System Assembly

NO.	Description	Part NO.	Qty.
73	Rip fence	JL26060002C	1
74	Lock plate	JXBS2001060001	1
75	Screw	M8X25GB70Z	2
76	Washer	WSH8GB97D1Z	2
77	Fence bracket	JXBS2001060002-001	1
78	Handle	JXBS2201061000-001	1
79	Fence guide	JXBS2001060005	1
80	Rod	JXBS2001060003	2
81	Hex nut	JXBS2001060004	2
82	Washer	WSH10GB97D1Z	7
83	Hex nut	M10GB6170Z	4
84	Trunnion Assembly	JXBS2001031100	1
85	Nut	M12X60GB77B	3
86	Hex nut	M12GB6172Z	4
87	Big washer	WSH12GB96Z	8
88	Hex nut	M12GB6170Z	4
89	Nut	M12X50GB77B	1
90	Nut	M3X5GB818Z	2
91	Indicator	JXBS2401031008	1
92	Scale	JXBS2001031004A	1
93	Rivet	RVT2D5X5GB827C	3
94	Trunnion	JXBS2001031001	1
95	Lock nut	JL29042004	1
96	Guide shaft	JXBS2001031002	1
97	Nut	M6X10GB70Z	2
98	Big washer	WSH6GB5287Z	2
99	Bolt	M12X100GB14Z	1
100	Spring washer	WSH10GB93Z	2
101	Washer	WSH12GB97D1Z	1
102	Locking handle	KT5B-1-A-M12X95	1
103	Gear shaft	JMBS2201032200	1
104	Big washer	WSH10GB96Z	2
105	Bolt	M10X40GB5783Z	2
106	Table	BS5001030002-001G	1
107	Lock nut	M5GB889Z	4
108	Table insert	BS5001030001-001S	1
109	Nut	M5X30GB77B	4

Table Assembly

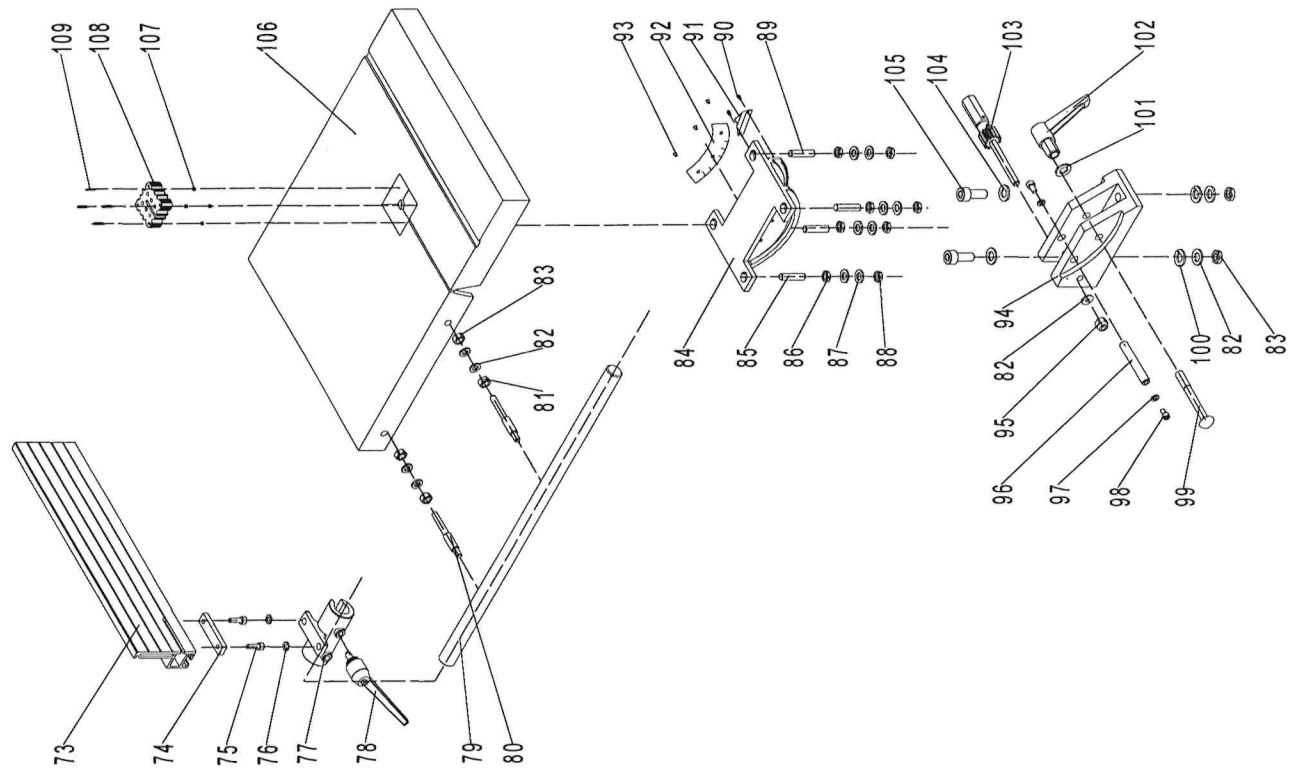

NO.	Description	Part NO.	Qty.
112	Washer	BS5001040007	1
113	Tube	BS5001040006	1
114	Spring washer	WSH50GB1972B	8
115	Flat washer	WSH24GB97D1Z	1
116	Plate	BS5001040009	1
117	Roll pin	PIN3X30GB879D1B	1
118	Thread rod	BS5001040004	1
119	Bearing	BRG51104GB301	2
120	Bracket	BS5001040002	1
121	Knob	1904011	1
122	Bracket	BS5001040005	1
123	Handwheel	JXBS2001040005	1
124	Set screw	M6X12GB78B	1
125	Pan head screw	M10X30GB70Z	2
126	Spring washer	WSH10GB93Z	2
127	Bracket	BS5001040003	1
128	Sliding rod	BS5001040001	2
129	Upper shaft	BS5001040008	1
130	Bracket	JXBS1401030001	1
131	Set screw	M8X20GB80B	1
132	Spring washer	WSH10GB93B	2
133	Hex nut	M10GB6170Z	2
134	Thread rod	JXBS1801030007	1
135	Lock nut	M10GB889Z	2
136	Spring washer	WSH10GB97D1Z	2
137	Bolt	JXBS1801030006	2
138	Flat washer	WSH12GB97D1Z	2
139	Spring washer	WSH12GB93Z	2
140	Hex nut	M12GB923Z	2

Blade Tension Assembly

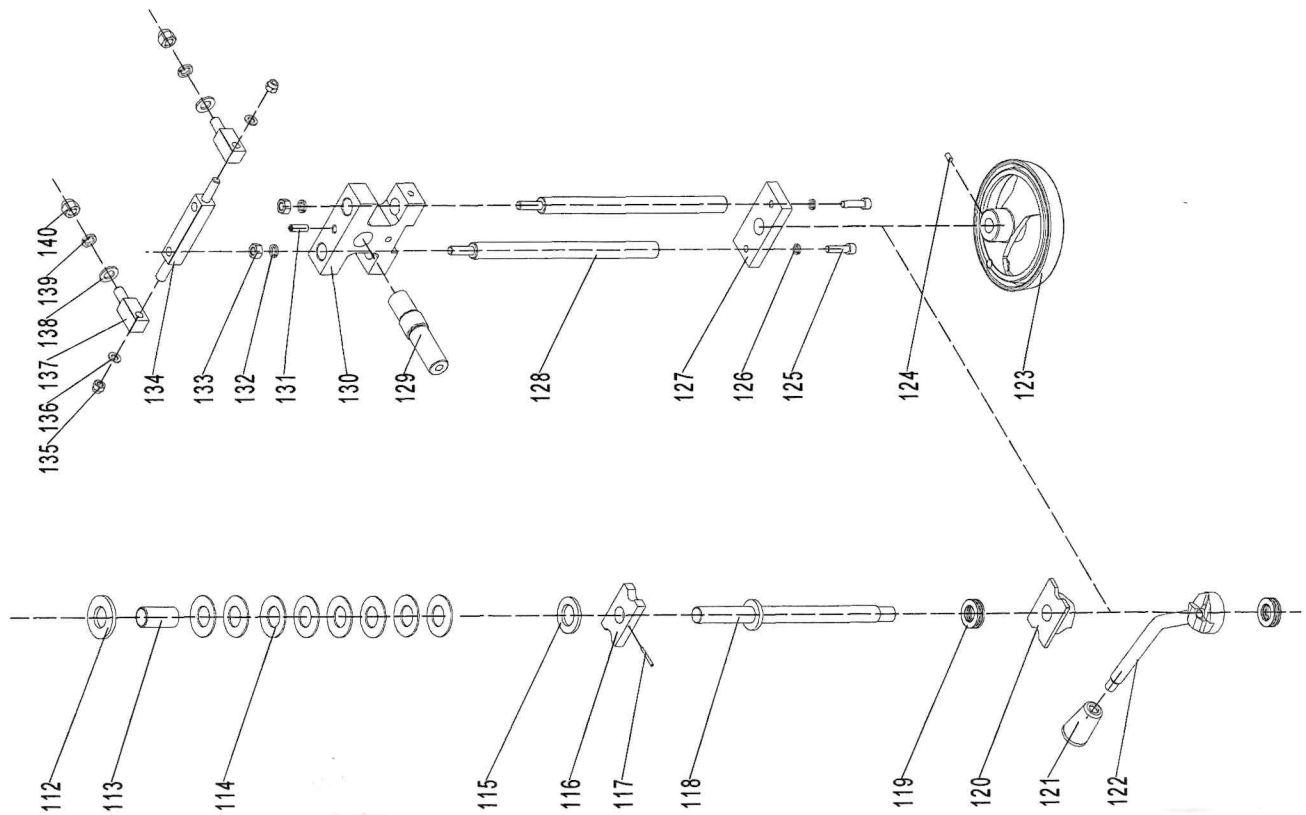

NO.	Description	Part NO.	Qty.
141	hex bolt	MBX20GB5783Z	4
142	big washer	WSH8GB96Z	4
143	lock handle	JL26040015-001S	1
144	Bracket	JL26040008	1
145	Set screw	M6X12GB77Z	4
146	Gear	1501006	1
147	Plate	JL26040007	1
148	screw	JL26040006	1
149	cover	BS5001050001	1
150	screw	M8X16GB70Z	4
151	cover	BS5001050002	1
152	Pan head screw	M4X4GB823B	1
153	Rack	BS6001050001	2
154	screw	M4X10GB819Z	1
155A	Bracket	BS5001052001	3
156	screw	M8X20GB70Z	1
156A	Guide post	JL26041004	1
156B	screw	M8X16GB70Z	1
156C	tube	JL26041006	1
156D	screw	M8X30GB70Z	1
156E	screw	M8X40GB70Z	2
156F	tube	JL26041002	2
156G	Bearing	BRG6201-2RSGB276	5
156H	plat washer	WSH8GB97D1Z	3
156I	Guide shaft	JL26041003	3
156J	Upper guide	JL26041001	1
157			
158			
159	big washer	WSH6GB96Z	1
160	composite bolt	JL20061003A-001S	1
161	nut	M6X15GB/T17880D3Z	1
162	nut	M4X10GB818Z	4
163	observing window	JL29043001	1
164A	Blade guard	BS5001051000-126T	1
165	screw	M4GB6170Z	4
166	big washer	WSH5GB96Z	2
167	screw	M5X10GB70Z	2
168			
169	screw	M6X16GB70Z	2
170A	Guide post	BS5001050003	1
171	Pan head screw	M5X10GB818B	2
172	handle	1501009-20001S	1
173	big handwheel	JL26030012-001S	1
174	tube	JL26040003	1
175	Screw-locked ring	CLP-12GB884B	1
176	Set screw	M5X8GB78Z	1
177	Worm	JL26040004	1

Upper guide Assembly

